

# 底盤使用說明

## 調整座椅升降&後仰

### a. 調整升降與後仰控制桿

1. 向前下壓  
座椅高度升降
2. 向外拉  
開啟椅背後仰功能
3. 向內推  
鎖定椅背後仰角度



## 調整滑動坐殼

### b. 調整滑動坐殼控制桿

1. 身體坐在椅子上  
向上拉起調整桿  
向前滑動坐殼
2. 身體離開椅子  
向上拉起調整桿  
滑動坐殼自動收回



## 調整椅背後仰力道

### c. 調整椅背後仰力道彈簧盒

1. 順時針轉動  
後仰力道小
2. 逆時針轉動  
轉緊後仰力道大



# Kabuto™

Ergonomic Chair

BACKBONE

## 人體工學機能椅 組裝使用說明書

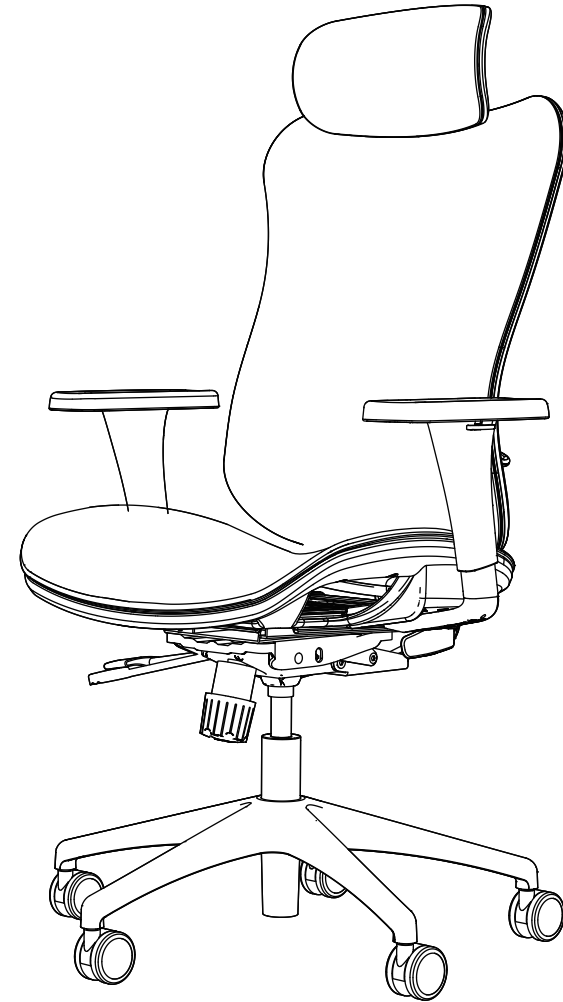

# 正確坐姿 遠離不適

## 1 調整桌椅，保持正確姿勢

調整椅面高度，讓下肢與上半身呈90度直角，使雙腳平放地板上，勿翹腳、手肘自然垂放在桌上也是呈90度，方便操作滑鼠。

## 2 記得利用椅靠與腰靠

確認身體與腰能平貼椅子背靠與腰靠，肩膀與臀部之間應形成一條垂直線。

## 3 調整螢幕高度

調整螢幕高度，避免螢幕角度過於向上或是向下，使眼睛視角能平視螢幕最上排的字。

## 4 定時讓自己休息

任何姿勢只要維持過久，對身體與脊椎都是一種負擔，建議強迫自己定時30分~1小時即起身站立或從事其他活動與休息。

### 腰靠操作使用說明

#### 調整腰靠升降

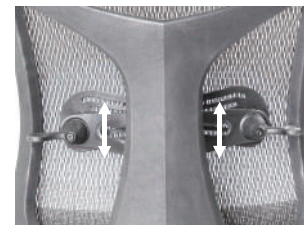
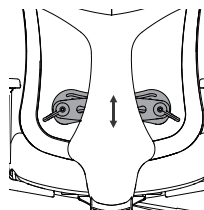

**操作方式**  
推動腰靠調整升降

#### 調整腰靠鬆緊

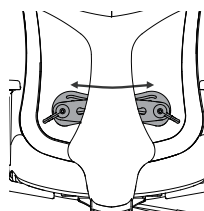

**操作方式**  
向下轉動旋鈕調整腰靠  
向上轉動旋鈕調整腰靠

### 椅背操作使用說明

#### 調整椅背升降

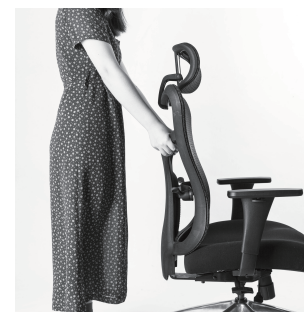
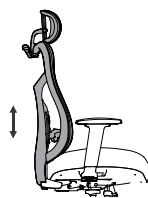

**操作方式**  
拉動背框調整高低

#### 調整椅背後仰



**操作方式**  
向外拉開控制桿  
開啟椅背後仰功能  
向內推進控制桿  
鎖定椅背後仰角度

## 頭枕&扶手操作使用說明

### 調整頭枕升降

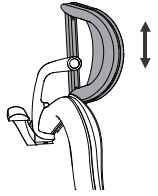

**操作方式**  
向上/向下調整高低

### 調整頭枕角度

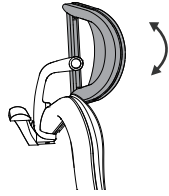

**操作方式**  
向上/向下調整角度

## 扶手操作說明

### 調整扶手升降

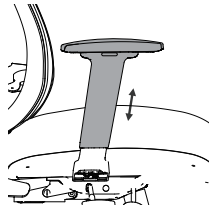

**操作方式**  
按壓扶手墊下的按鍵  
調整扶手升降

### 調整扶手墊

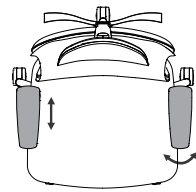

**操作方式**  
推/轉扶手墊調整

# 3

顯示器平直面向臉  
不要傾斜

# 2

頭保持正中姿勢  
眼睛水平或略低  
可直視螢幕最上排文字

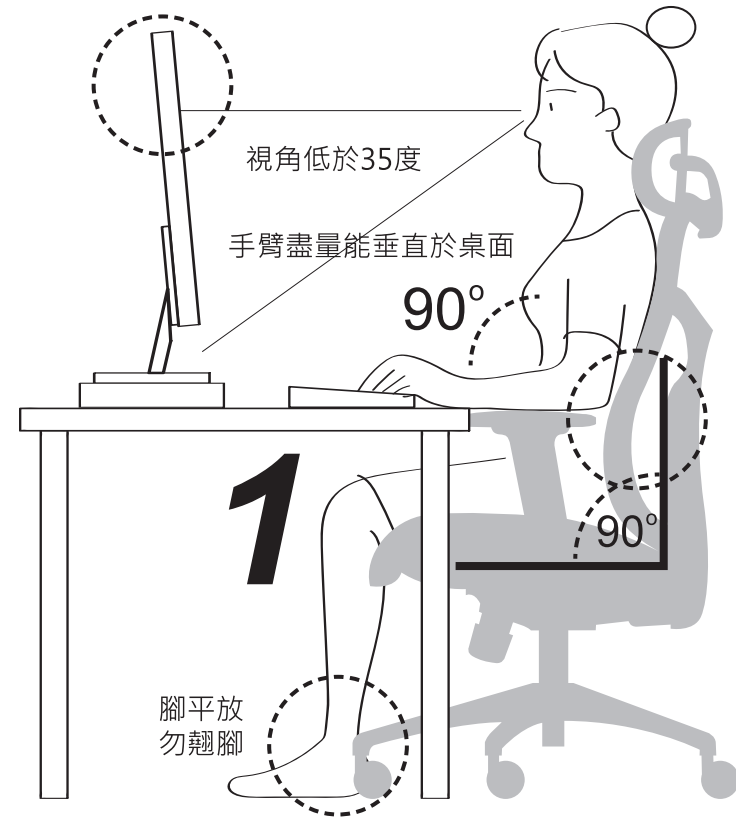

# 享受各種貼心功能!

感謝您購入 Kabuto™ 人體工學椅  
在組裝之前,先了解各種貼心功能吧!



承重120kg

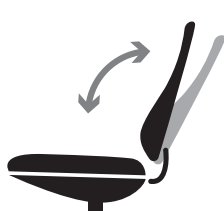

分離傾仰

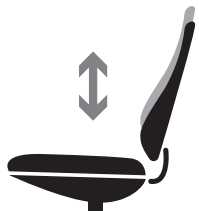

椅背調整高度



氣壓調整高度

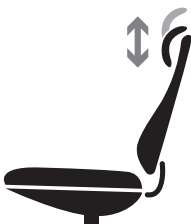

頭枕高度調節



頭枕角度調節

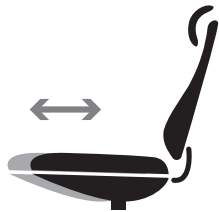

椅墊前後移動

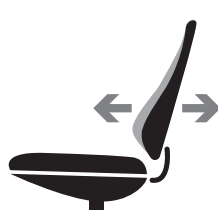

腰靠深度調整

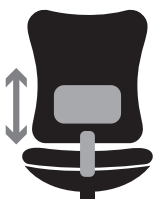

腰靠高低調整



扶手高度調整



扶手前後移動



扶手左右角度



貼心衣架



靜音滑輪

## STEP 5 : 氣壓棒插入椅腳

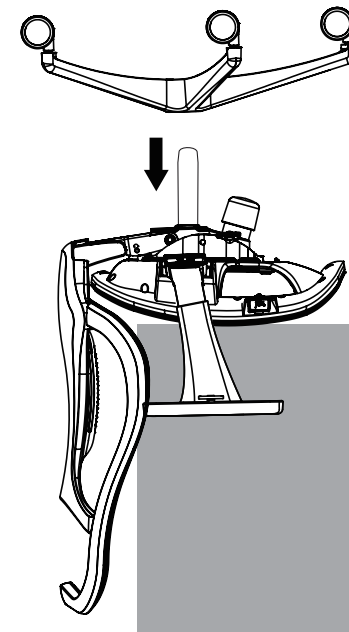

**Tips** 完成 Step 5 將椅子轉回正確方向

## STEP 6 : 鎖上衣架 & 頭枕組

- ⑩ 頭枕
- ⑪ 衣架
- ⑫ 衣架頭枕螺絲
- ⑬ 頭枕飾蓋
- A 六角扳手



**!** 頭枕與衣架配件需同時鎖附，  
不能單獨組裝，以免造成背框損壞。

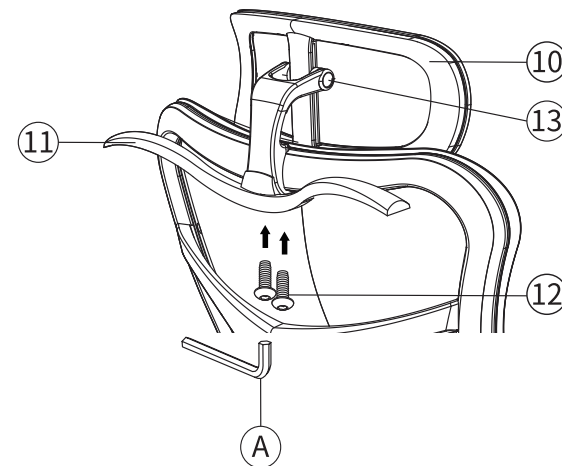

**Tips** 勿使用電動起子,請用手將螺絲預鎖1-2圈後,再用六角扳手往洞口方向施力鎖緊。  
如欲調整頭枕升降力道,請調整飾蓋內的十字螺絲。



### STEP 3 : 氣壓棒插入椅座

⑦ 防爆氣壓棒

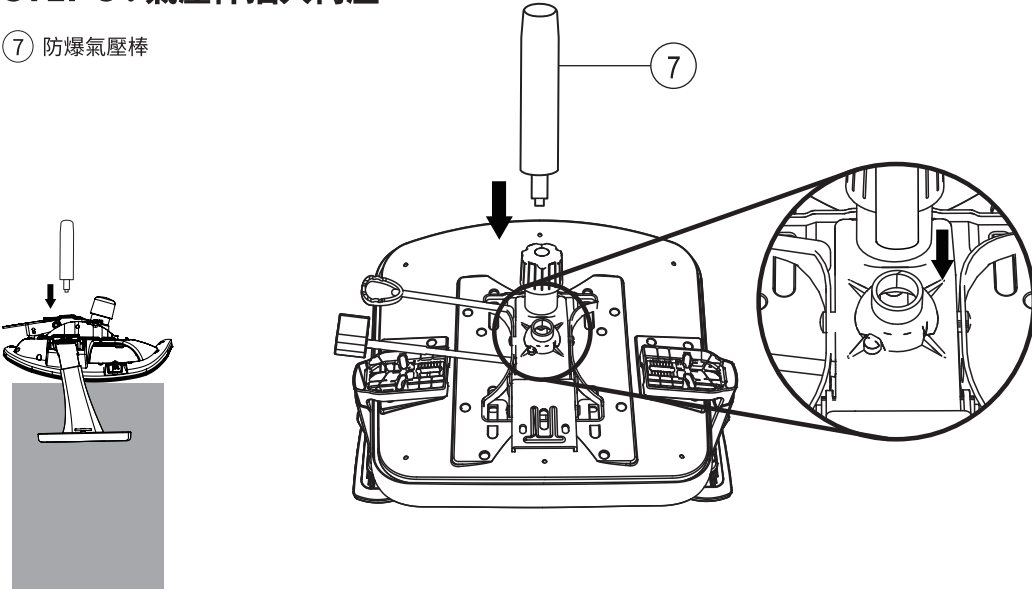

**Tips** 防爆氣壓棒直接插入椅座中心的孔內。

泡綿座尺寸

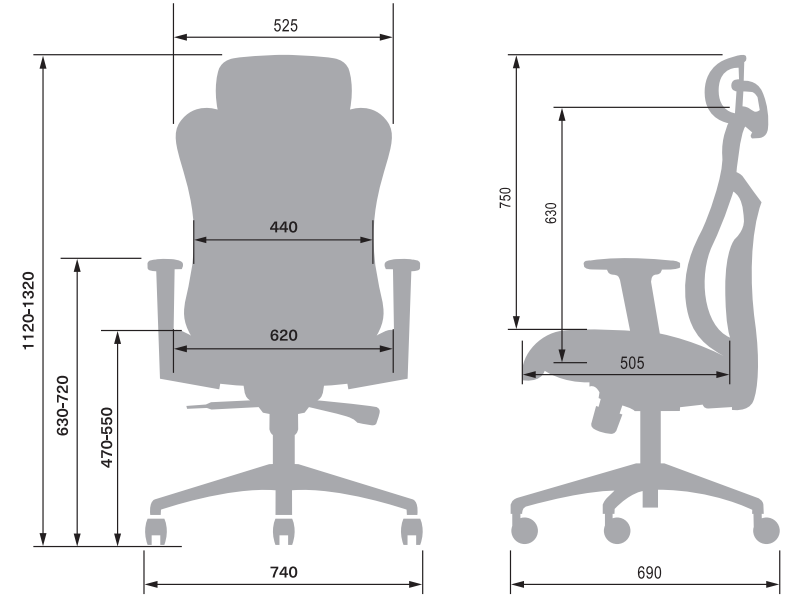

### STEP 4 : 安裝椅輪

⑧ 椅腳

⑨ 靜音輪

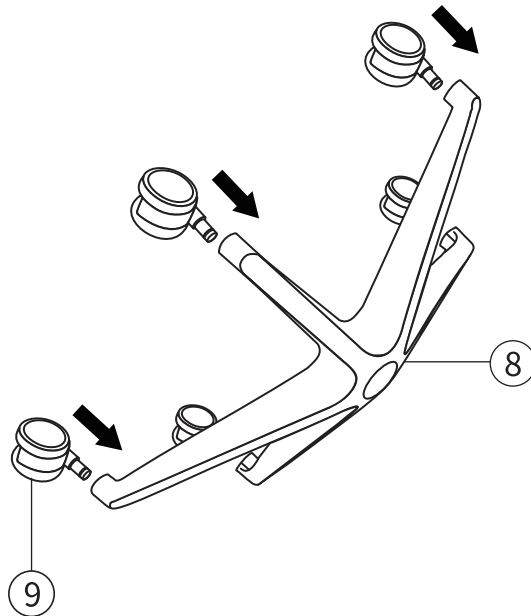

網座尺寸

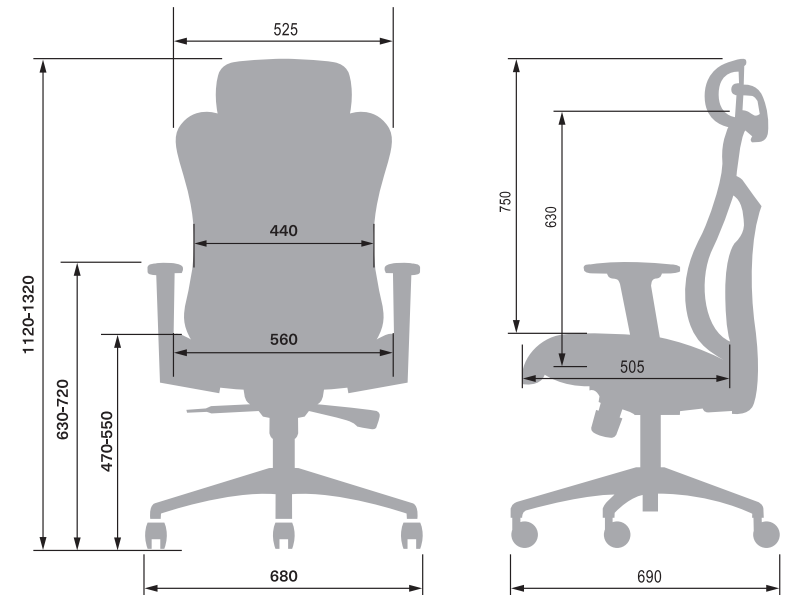

# 箱內零件

**STEP 1**

① 椅座 x1	② 左扶手 x1
③ 右扶手 x1	④ 扶手螺絲 x6

**STEP 2**

⑤ 椅背 x1
⑥ 椅背螺絲 x3

**STEP 3**

⑦ 防爆氣壓棒 x1
------------------

**STEP 4**

⑧ 椅腳 x1	⑨ 靜音輪 x5
---------------	----------------

**STEP 6**

⑩ 頭枕 x1	⑪ 衣架 x1
⑫ 衣架頭枕螺絲 x2	⑬ 頭枕飾蓋 x2

**手工具**

A 六角板手 x1
-----------------

**!** 建議至少每三個月檢查並重新鎖緊所有螺絲和零件。  
如果有螺絲或零件鬆脫，請重新鎖緊後再使用，以確保安全。

## STEP 1: 安裝左右扶手

- ① 椅座
- ② 左扶手
- ③ 右扶手
- ④ 扶手螺絲
- A 六角板手

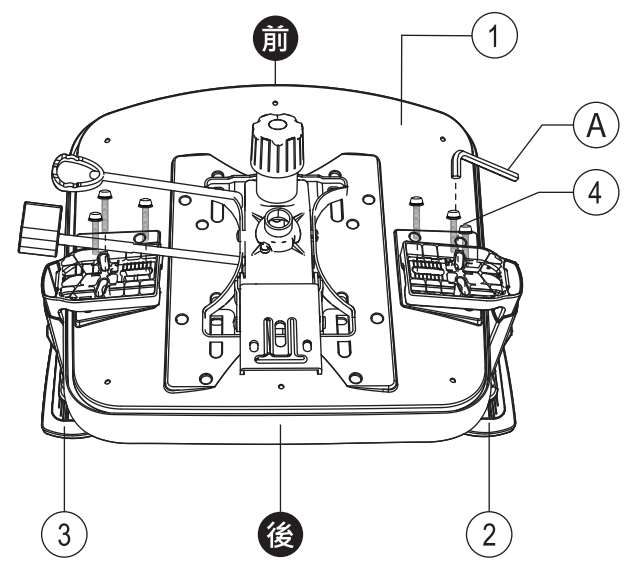
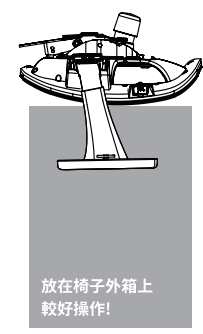

**Tips** 扶手底部有標示左扶手(L)/右扶手(R)，請留意!

## STEP 2: 椅墊 & 椅背結合

- ⑤ 椅背
- ⑥ 椅背螺絲
- A 六角板手

