











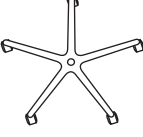

椅款組裝說明

不同椅款適用螺絲

箱內零件						
頭枕部分皆已預先鎖好			G 為扶手螺絲 H 為椅背鎖底盤之螺絲，H 與 G 與 J 已預鎖。			
						
A	B	C	D	E	F	
			Kangaroo & Koala G x 6  H1 x 1  H2 x 2  J x 4 (網座專屬) 		其他椅款 G x 6  H x 3  J x 4 (網座專屬) 	

STEP 1

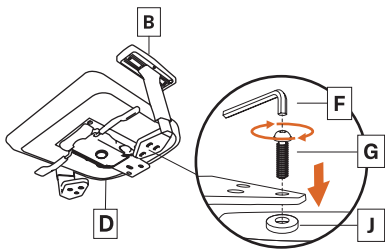

STEP 2

零件包中的墊片可根據個人情況，自行加在背支架螺絲上。

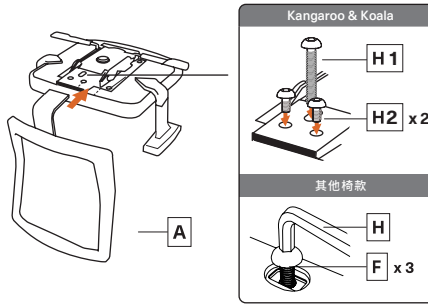

STEP 3

氣壓為卡榫式，無須螺絲，一經插上無法拆除。

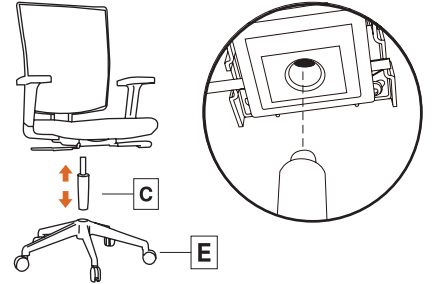









建議將椅子放置在紙箱或桌面上更加方便組裝！

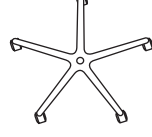

組裝前請確認螺絲與配件是否備齊，一經組裝將影響退貨權益。

Gull™ 組裝說明

安裝前請先確認螺絲數量

箱內零件					
H 螺絲已預鎖在相對位置上					
					
A	B	C	D	E	F
			G x 2  H x 4 		

STEP 1

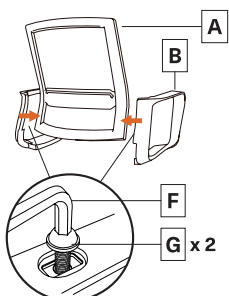

STEP 2

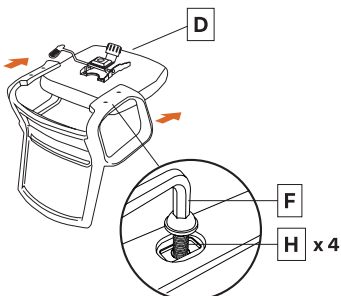

STEP 3

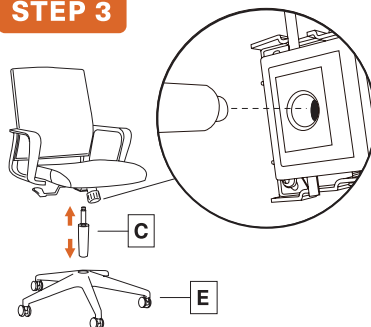

Backbone® 椎座工學

如有後續組裝問題，歡迎掃描下方的 QR CODE，觀看我們線上組裝影片



或聯絡專業組裝顧問：(02)2356-9828

椅款使用說明

我們提供各配置的使用教學

坐墊坐姿小教室

調整至你最舒適的姿勢

底盤使用說明

底盤已經事先鎖好

STG	SXTG	XTG
<p>a. 調整升降與後仰 向上扳 - 高度升降 向外拉 - 開啟後仰功能 向內推 - 關閉後仰功能</p> <p>b. 旋轉可調整後仰力道</p>	<p>a. 調整升降: 向上扳 - 高度升降</p> <p>b. 調整坐墊: 往上扳, 屁股往前 可往前5cm深度</p> <p>c. 調整後仰功能: 往後撥 - 開啟後仰功能 往前撥 - 鎖定三段 (135-115-90) 往後dia一聲 - 回到原位</p>	<p>a. 調整升降: 向上扳 - 高度升降</p> <p>b. 調整後仰功能: 往後撥 - 開啟後仰功能 往前撥 - 鎖定三段 (135-115-90) 往後dia一聲 - 回到原位</p>

頭枕坐姿小教室

放置在脖子正後方 支撐頸椎

頭枕使用說明

2D	2D	1D
Kangaroo/Bear	其他椅款	Deer/Sheep
<p>⇕ 上下調節</p> <p>↻ 可轉面調整</p>	<p>⇕ 上下調節</p> <p>↻ 可轉面調整</p> <p>拉住A點做調整</p>	<p>⇕ 上下調節</p>

扶手坐姿小教室

調整到適當位置 使手肘有支撐

扶手使用說明

1D	3D	3D	3D
升降扶手	升降/前後扶手	旋轉扶手	肘拖扶手
扶手升降按鈕			
扶手墊前後左右按鈕			
扶手旋轉收起			<p>多角度旋轉 旋轉操作不需按鈕，直接調節即可。 扶手墊往後到底，便不能再左右調整。</p>

高承重氣壓棒

耐磨椅輪滑動更便捷

氣壓棒 & 椅輪

Tips
建議將椅子放置在紙箱或桌面上更方便組裝!

氣壓棒
請對準底盤底下之孔洞向上安插即可

椅輪
用力往內擠可裝上
欲拆卸便直接拔下即可